

WT588D VOICE CHIP/MODULE APPLICATION CIRCUIT

1.WT588D MODULE INNER CIRCUIT	2
2.WT588D VOICE CHIP/ MODULE DAC OUTPUT APPLICATION CIRCUIT(CONNECT AMPLIFIER).....	3
3. WT588D VOICE CHIP/ MODULE DAC OUTPUT APPLICATION CIRCUIT(CONNECT AUDION)	4
4.WT588D VOICE CHIP/ MODULE PWM OUTPUT APPLICATION CIRCUIT	5
5.WT588D VOICE CHIP/ MODULE MP3 MODE APPLICATION CIRCUIT	6
6.WT588D VOICE CHIP/MODULE KEY MODE APPLICATION CIRCUIT	8
7.WT588D VOICE CHIP/MODULE PARALLEL MODE APPLICATION CIRCUIT	9
8.WT588D VOICE CHIP/MODULE MATRIX 3x8 KEY MODE APPLICATION CIRCUIT	11
9.WT588D VOICE CHIP/MODULE ONE-LINE SERIAL MODE APPLICATION CIRCUIT.....	13
10.WT588D VOICE CHIP/MODULE THREE-LINE SERIAL MODE APPLICATION CIRCUIT.....	14
11.WT588D VOICE CHIP/MODULE THREE-LINE I/O EXTENSION MODE APPLICATION CIRCUIT.....	16

Note:

Revised reset circuit and PWM output circuit on 20th Jan. ,2009

1.WT588D MODULE INNER CIRCUIT

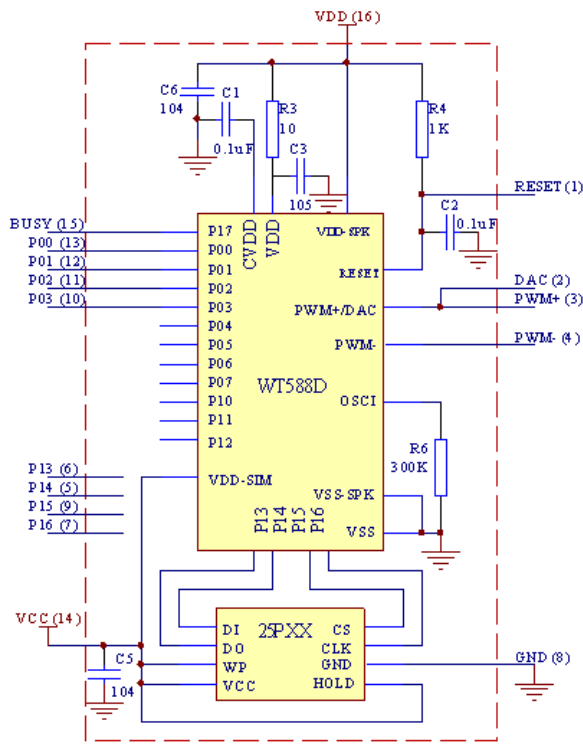

WT588D-16PIN MODULE

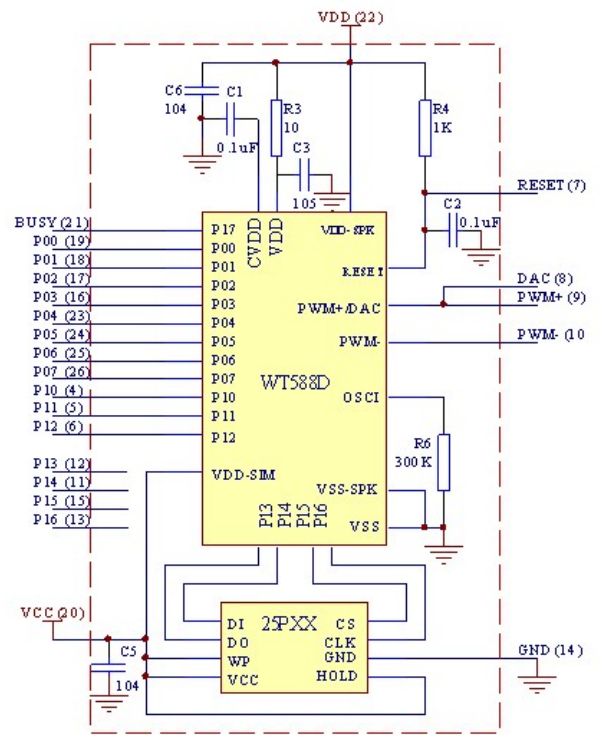

WT588D-28PIN MODULE

WT588D module including FLASH and relative external circuit, connect to control parts, power and speaker ,can make it works.

BUSY signal : Connect LED to busy port for indicating the play status, you can set it light or extinguished in the PC software when it is playing the voice.

Power supply : When 5V power input, connect two diodes(such as IN4001/4007) to VCC by serial, when 3V power input, connect power to VCC directly.

PWM audio output:Direct drive speaker, connect PWM+ and PWM- to speaker. PWM+ and PWM- can not short circuit and can not connect capacitor or resistor to GND. If necessary to connect to amplifier under this audio output mode, can apply difference mode output to amplifier.

DAC audio output:External amplifier to drive speaker. Can not drive speaker directly. PWM+/DAC for audio output, PWM- is not connect. DAC connect a 1.2K resistor and a 104 capacitor to GND, and then audio output to amplifier.

DAC audio output: External amplifier to drive speaker. Can not drive speaker directly. PWM+/DAC for audio output, PWM- is not connect. DAC need to connect a 1.2K resistor and a 104 capacitor to GND (such as R2 and C4 in the circuit), and then audio output to amplifier.

The oscillating resistor R6 , capacitors C3, C5 **should be close to WT588D** on the circuit board. Ensure it works normally.

4.WT588D VOICE CHIP/ MODULE PWM OUTPUT APPLICATION CIRCUIT

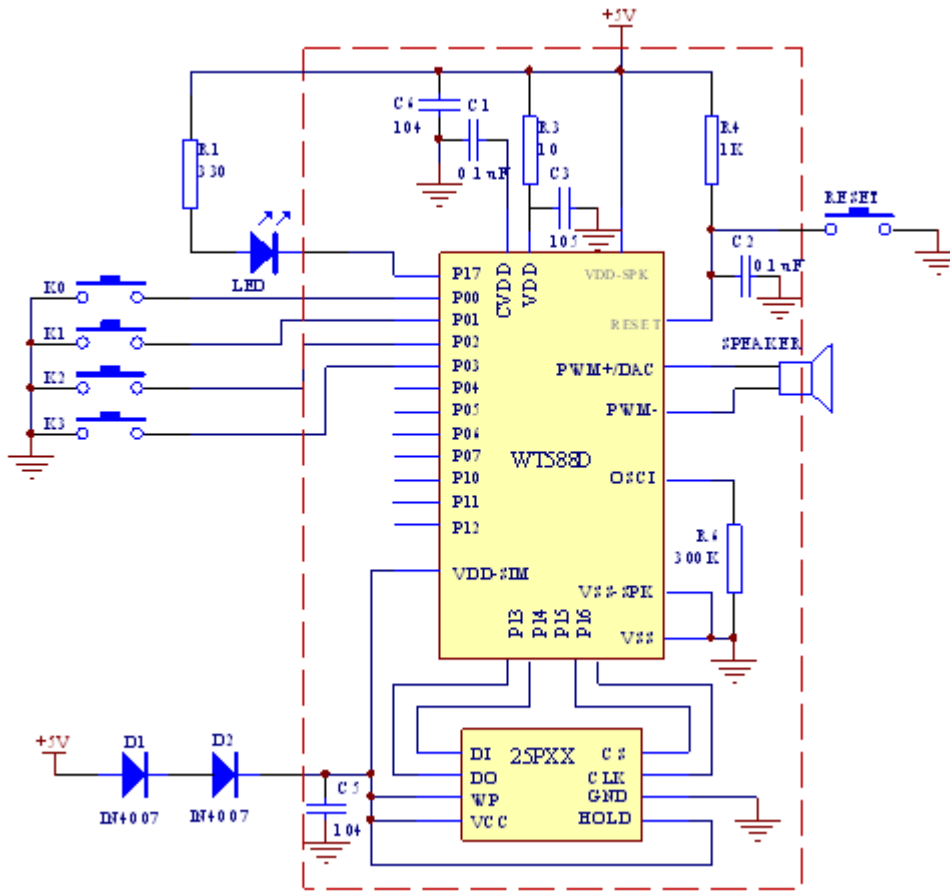

Within the red broken line circuit is WT588D module in the above circuit. If apply module solution, only think about outer circuit. If apply chip solution, think about whole circuit.

Software setting: key mode

I/O definition: Choose I/O P00,P02,P03 as trigger port, When SPI-FLASH is programmed ,define the keys on trigger port as trigger mode which can trigger to play voice, and works.

BUSY signal: P17 is BUSY output, can set the LED light or extinguished when playing voice

Reset circuit: add a touch key on RESET port , can reset manually.

Oscillating resistor: The resistance of R6 in the circuit is default. Different resistance make the playback speed difference. Different sampling rate, different resistance, refer to "ATTENTIONS IN APPLICATION". If no special requirements,300K is recommended.

Module application circuit power supply: When 5V power input, connect two diodes(such as IN4001/4007) to VCC by

corresponding key, K0 is STOP, K1 is PALY/PAUSE, K2 is PREVIOUS, K3 is NEXT, K4 is VOI+, K5 is VOL- .

BUSY singal: P17 is BUSY output, can set the LED light or extinguished when playing voice

Reset circuit: add a touch key on RESET port , can reset manually.

Oscillating resistor: The resistance of R6 in the circuit is default. Different resistance make the playback speed difference. Different sampling rate, different resistance, refer to “ATTENTIONS IN APPLICATION”. If no special requirements,300K is recommended.

Module application circuit power supply: When 5V power input, connect two diodes(such as IN4001/4007) to VCC by serial, when 3V power input, connect power to VCC directly.

Chip application circuit power supply: When 5V power input, connect two diodes (IN4001/4007)to FLASH positive power input port to make the voltage suit FLASH, FLASH working voltage form 2.8V to 3.5V. When 3V power input, connect power to FLASH power input directly.

PWM audio output: Direct drive speaker, connect PWM+ and PWM- to speaker. PWM+ and PWM- can not short circuit and can not connect capacitor or resistor to GND. If necessary to connect to amplifier under this audio output mode, can apply difference mode output to amplifier.

DAC audio output: External amplifier to drive speaker. Can not drive speaker directly. PWM+/DAC for audio output, PWM- is not connect. DAC need to connect a 1.2K resistor and a 104 capacitor to GND, and then audio output to amplifier. Refer to “2.WT588D VOICE CHIP/ MODULE DAC OUTPUT APPLICATION CIRCUIT(CONNECT AMPLIFIER)”

The oscillating resistor R6 , capacitors C3, C5 **should be close to WT588D** on the circuit board. Ensure it works normally.

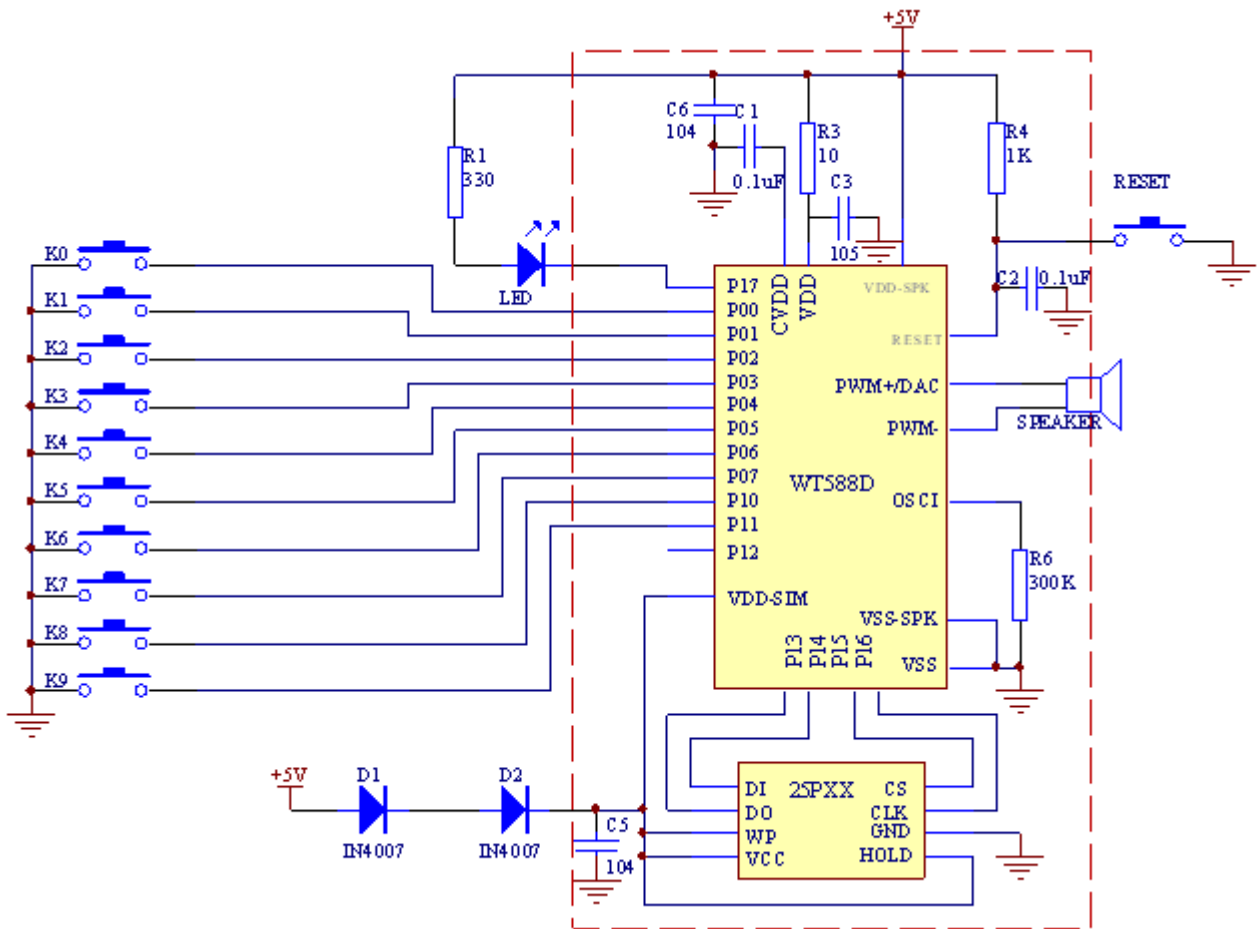
6.WT588D VOICE CHIP/MODULE KEY MODE APPLICATION CIRCUIT

Within the red broken line circuit is WT588D module in the above circuit. If apply module solution, only think about outer circuit. If apply chip solution, think about whole circuit.

Software setting: key mode

I/O definition: Choose I/O P00,P01,P02,P03 ,P04,P05,P06,P07,P10,P11 as trigger port , Each I/O's corresponding key to trigger, defined as every trigger mode, such as EDGE RETRIGGER.....

BUSY signal: P17 is BUSY output, can set the LED light or extinguished when playing voice

Reset circuit: add a touch key on RESET port , can reset manually.

Oscillating resistor: The resistance of R6 in the circuit is default. Different resistance make the playback speed difference. Different sampling rate, different resistance, refer to "ATTENTIONS IN APPLICATION". If no special requirements,300K is recommended.

Module application circuit power supply: When 5V power input, connect two diodes(such as IN4001/4007) to VCC by serial, when 3V power input, connect power to VCC directly.

Chip application circuit power supply: When 5V power input, connect two diodes (IN4001/4007) to FLASH positive power input port to make the voltage suit FLASH, FLASH working voltage form 2.8V to 3.5V. When 3V power input, connect power to FLASH power input directly.

PWM audio output: Direct drive speaker, connect PWM+ and PWM- to speaker. PWM+ and PWM- can not short circuit and can not connect capacitor or resistor to GND. If necessary to connect to amplifier under this audio output mode, can apply difference mode output to amplifier.

DAC audio output: External amplifier to drive speaker. Can not drive speaker directly. PWM+/DAC for audio output, PWM- is not connect. DAC need to connect a 1.2K resistor and a 104 capacitor to GND, and then audio output to amplifier. Refer to “2.WT588D VOICE CHIP/ MODULE DAC OUTPUT APPLICATION CIRCUIT(CONNECT AMPLIFIER)”

The oscillating resistor R6 , capacitors C3, C5 **should be close to WT588D** on the circuit board. Ensure it works normally.

7.WT588D VOICE CHIP/MODULE PARALLEL MODE APPLICATION CIRCUIT

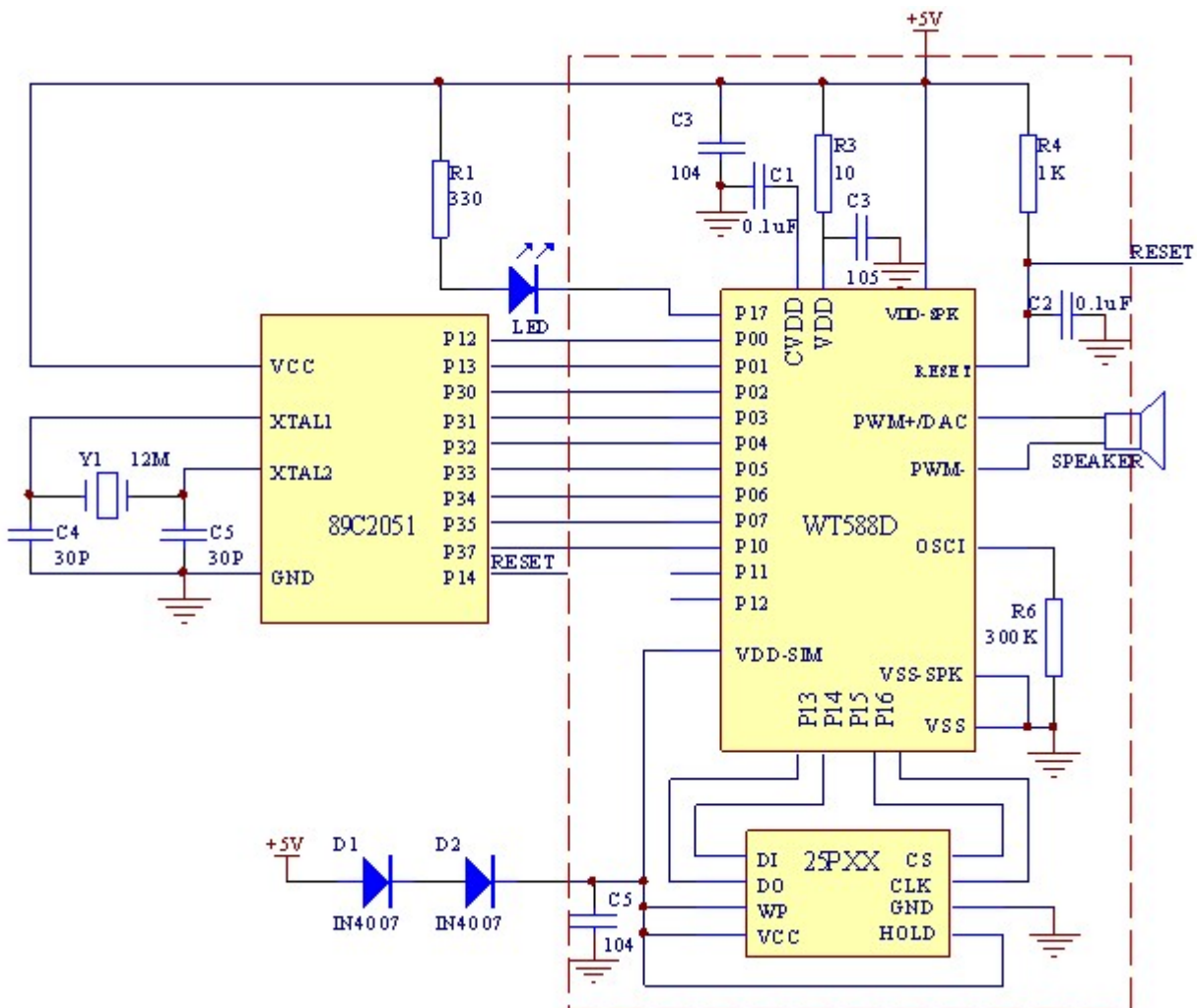

Within the red broken line circuit is WT588D module in the above circuit. If apply module solution, only think about outer circuit. If apply chip solution, think about whole circuit.

Software setting: parallel mode

I/O definition: I/O P00 is SBT audio trigger port. Can be defined as EDGE RETRIGGER trigger mode or other trigger mode which can trigger voice to play. P01,P02,P03,P04,P05,P06,P07,P10 are address I/Os. Address bit P01→P10 from low to high.

BUSY signal: P17 is BUSY output, can set the LED light or extinguished when playing voice

Reset circuit :MCU (89C2051)gives WT588D a reset signal to reset before control WT588D.

Oscillating resistor: The resistance of R6 in the circuit is default. Different resistance make the playback speed difference. Different sampling rate, different resistance, refer to “ATTENTIONS IN APPLICATION”. If no special requirements,300K is recommended.

Module application circuit power supply: When 5V power input, connect two diodes(such as IN4001/4007) to VCC by serial, when 3V power input, connect power to VCC directly.

Chip application circuit power supply: When 5V power input, connect two diodes (IN4001/4007) to FLASH positive power input port to make the voltage suit FLASH, FLASH working voltage form 2.8V to 3.5V. When 3V power input, connect power to FLASH power input directly.

PWM audio output: Direct drive speaker, connect PWM+ and PWM- to speaker. PWM+ and PWM- can not short circuit and can not connect capacitor or resistor to GND. If necessary to connect to amplifier under this audio output mode, can apply difference mode output to amplifier.

DAC audio output: External amplifier to drive speaker. Can not drive speaker directly. PWM+/DAC for audio output, PWM- is not connect. DAC need to connect a 1.2K resistor and a 104 capacitor to GND, and then audio output to amplifier. Refer to “2.WT588D VOICE CHIP/ MODULE DAC OUTPUT APPLICATION CIRCUIT(CONNECT AMPLIFIER)”

The oscillating resistor R6 , capacitors C3, C5 **should be close to WT588D** on the circuit board. Ensure it works normally.

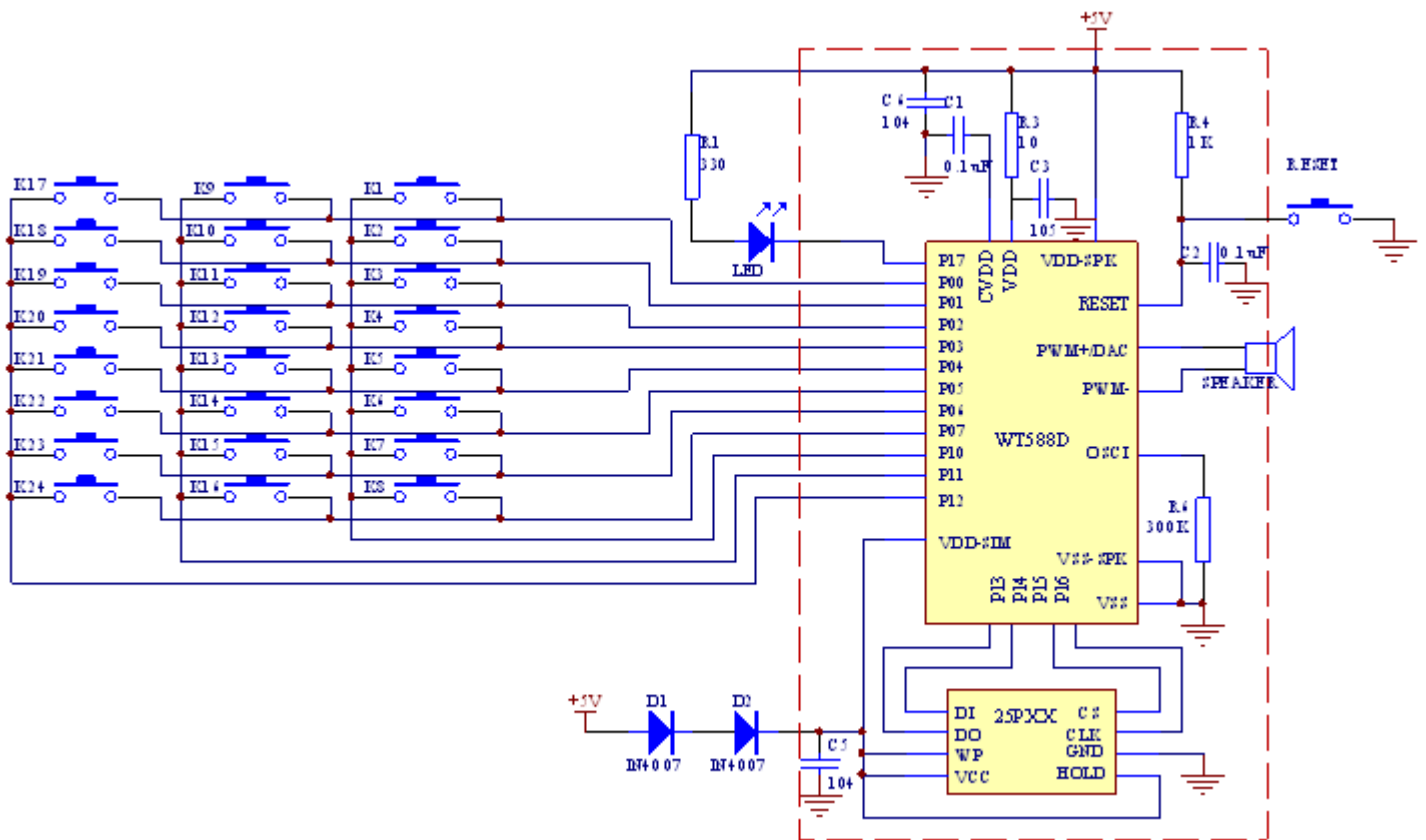
8.WT588D VOICE CHIP/MODULE MATRIX 3x8 KEY MODE APPLICATION CIRCUIT

Within the red broken line circuit is WT588D module in the above circuit. If apply module solution, only think about outer circuit. If apply chip solution, think about whole circuit.

Software setting: matrix 3X8 key mode

I/O definition: I/O P10,P11,P12 separate defined as matrix column R1,R2,R3 input port.

P00,P01,P02,P03,P04,P05,P06,P07 separate defined as matrix row L1,L2,L3,L4,L5,L6,L7 input port, Use K1 to short touch P00 and P10 to trigger first address's voice. K2 for second address's voice,.....K24 for twenty fourth address's voice.

BUSY signal: P17 is BUSY output, can set the LED light or extinguished when playing voice

Reset circuit: add a touch key on RESET port , can reset manually.

Oscillating resistor: The resistance of R6 in the circuit is default. Different resistance make the playback speed difference. Different sampling rate, different resistance, refer to "ATTENTIONS IN APPLICATION". If no special requirements,300K is recommended.

Module application circuit power supply: When 5V power input, connect two diodes(such as IN4001/4007) to VCC by serial, when 3V power input, connect power to VCC directly.

Chip application circuit power supply: When 5V power input, connect two diodes (IN4001/4007) to FLASH positive power input port to make the voltage suit FLASH, FLASH working voltage form 2.8V to 3.5V. When 3V power input, connect power to FLASH power input directly.

PWM audio output: Direct drive speaker, connect PWM+ and PWM- to speaker. PWM+ and PWM- can not short circuit and can not connect capacitor or resistor to GND. If necessary to connect to amplifier under this audio output mode, can apply difference mode output to amplifier.

DAC audio output: External amplifier to drive speaker. Can not drive speaker directly. PWM+/DAC for audio output, PWM- is not connect. DAC need to connect a 1.2K resistor and a 104 capacitor to GND, and then audio output to amplifier. Refer to “2.WT588D VOICE CHIP/ MODULE DAC OUTPUT APPLICATION CIRCUIT(CONNECT AMPLIFIER)”

The oscillating resistor R6 , capacitors C3, C5 **should be close to WT588D** on the circuit board. Ensure it works normally.

Chip application circuit power supply: When 5V power input, connect two diodes (IN4001/4007) to FLASH positive power input port to make the voltage suit FLASH, FLASH working voltage form 2.8V to 3.5V. When 3V power input, connect power to FLASH power input directly.

PWM audio output: Direct drive speaker, connect PWM+ and PWM- to speaker. PWM+ and PWM- can not short circuit and can not connect capacitor or resistor to GND. If necessary to connect to amplifier under this audio output mode, can apply difference mode output to amplifier.

DAC audio output: External amplifier to drive speaker. Can not drive speaker directly. PWM+/DAC for audio output, PWM- is not connect. DAC need to connect a 1.2K resistor and a 104 capacitor to GND, and then audio output to amplifier. Refer to “2.WT588D VOICE CHIP/ MODULE DAC OUTPUT APPLICATION CIRCUIT(CONNECT AMPLIFIER)”

The oscillating resistor R6 , capacitors C3, C5 **should be close to WT588D** on the circuit board. Ensure it works normally.

10.WT588D VOICE CHIP/MODULE THREE-LINE SERIAL MODE APPLICATION CIRCUIT

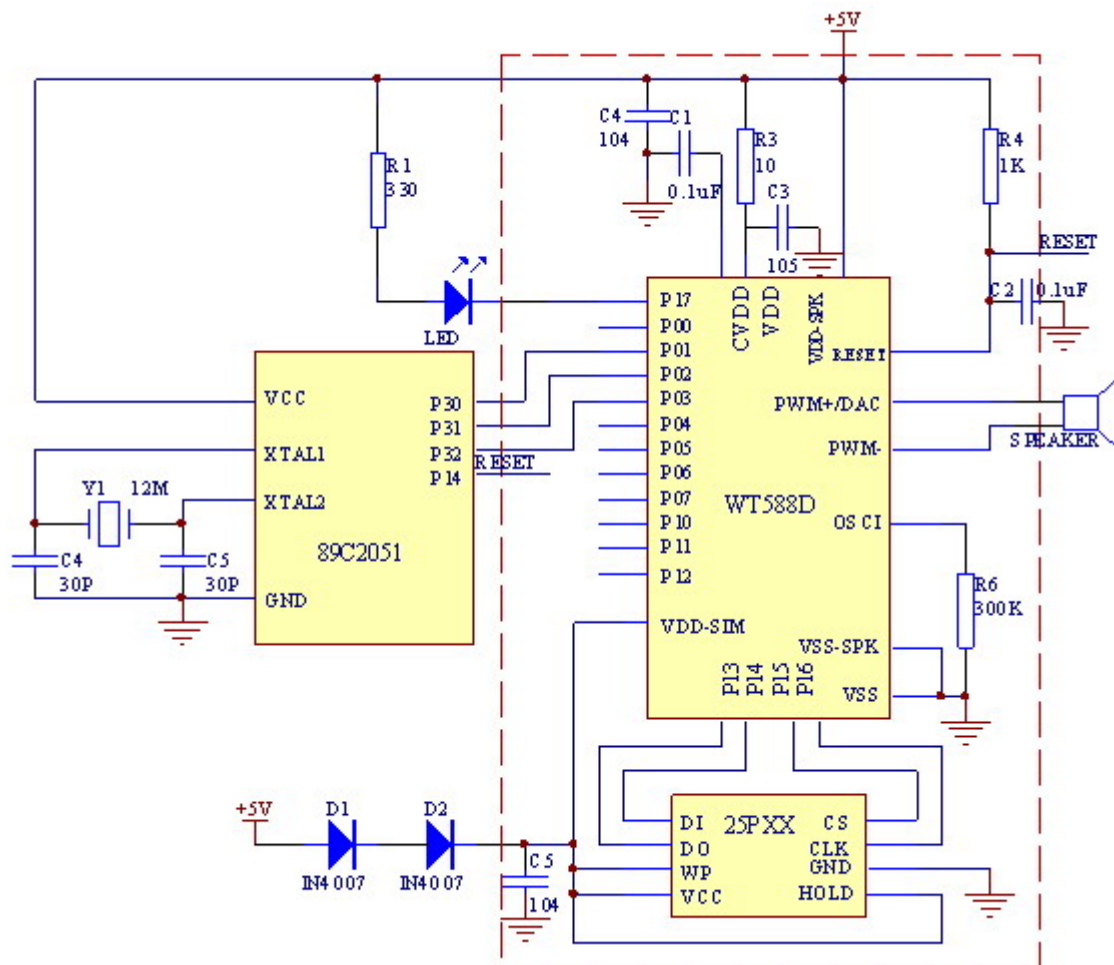

Within the red broken line circuit is WT588D module in the above circuit. If apply module solution, only think about outer circuit. If apply chip solution, think about whole circuit.

Software setting: three-line serial mode

I/O definition: I/O P01 defined as DATA in port, P02 is CS port, P03 is CLK port, MCU control WT588D voice chip by these port. In the three-line serial mode, P00, P04, P05, P06, P07, P10, P11, P12 are invalid.

BUSY signal: P17 is BUSY output, can set the LED light or extinguished when playing voice

Reset circuit: MCU (89C2051) gives WT588D a reset signal to reset before control WT588D.

Oscillating resistor: The resistance of R6 in the circuit is default. Different resistance make the playback speed difference. Different sampling rate, different resistance, refer to "ATTENTIONS IN APPLICATION". If no special requirements, 300K is recommended.

Module application circuit power supply: When 5V power input, connect two diodes (such as IN4001/4007) to VCC by serial, when 3V power input, connect power to VCC directly.

Chip application circuit power supply: When 5V power input, connect two diodes (IN4001/4007) to FLASH positive power input port to make the voltage suit FLASH, FLASH working voltage form 2.8V to 3.5V. When 3V power input, connect power to FLASH power input directly.

PWM audio output: Direct drive speaker, connect PWM+ and PWM- to speaker. PWM+ and PWM- can not short circuit and can not connect capacitor or resistor to GND. If necessary to connect to amplifier under this audio output mode, can apply difference mode output to amplifier.

DAC audio output: External amplifier to drive speaker. Can not drive speaker directly. PWM+/DAC for audio output, PWM- is not connect. DAC need to connect a 1.2K resistor and a 104 capacitor to GND, and then audio output to amplifier. Refer to "2.WT588D VOICE CHIP/ MODULE DAC OUTPUT APPLICATION CIRCUIT(CONNECT AMPLIFIER)"

The oscillating resistor R6, capacitors C3, C5 **should be close to WT588D** on the circuit board. Ensure it works normally.

Chip application circuit power supply: When 5V power input, connect two diodes (IN4001/4007) to FLASH positive power input port to make the voltage suit FLASH, FLASH working voltage form 2.8V to 3.5V. When 3V power input, connect power to FLASH power input directly.

PWM audio output: Direct drive speaker, connect PWM+ and PWM- to speaker. PWM+ and PWM- can not short circuit and can not connect capacitor or resistor to GND. If necessary to connect to amplifier under this audio output mode, can apply difference mode output to amplifier.

DAC audio output: External amplifier to drive speaker. Can not drive speaker directly. PWM+/DAC for audio output, PWM- is not connect. DAC need to connect a 1.2K resistor and a 104 capacitor to GND, and then audio output to amplifier. Refer to “2.WT588D VOICE CHIP/ MODULE DAC OUTPUT APPLICATION CIRCUIT(CONNECT AMPLIFIER)”

The oscillating resistor R6 , capacitors C3, C5 **should be close to WT588D** on the circuit board. Ensure it works normally.