

WTV-NAND RECORDING MODULE

1.FEATURES	1
2.BLOCK DIAGRAM	2
3. WORDS AND EXPRESSIONS	2
4.APPLICATIONS	2
5.PACKAGE AND PICTURE.....	2
6.PINS DESCRIPTION	3
7.CONTROL MODES	3
7.1 KEY MODE	3
7.1.1.MIC / LINE IN RECORD DESCRIPTION.....	3
7.1.2.PLAY MIC/LINE IN RECORDED VOICE	4
7.1.3. PLAY DOWNLOADED VOICE.....	4
7.1.4.ERASE MIC/LINE IN RECORDED VOICE	4
7.2.SPI SERIAL CONTROL.....	5
7.2.1.CODE AND RELATIVE FUNCTIONS	5
7.2.2.VOICE ADDRESSES.....	6
7.2.3. TIMING CHART FOR SENDING COMMOND COMMAND	6
7.2.4.TIMING CHART FOR SENDING COMMAND TO READ THE SPARE SPACE.....	7
8.APPLICATION CIRCUIT	7
8.1.WTV-NAND MODULE INNER CIRCUIT	7
8.2.KEY MODE (PWM OUTPUT)	8
8.3.KEY MODE (DAC OUTPUT)	9
8.4.SPI SERIAL CONTROL MODE (PWM OUTPUT).....	10
8.5.SPI SERIAL CONTROL MODE (DAC OUTPUT).....	11
9.SUPPLY INFORMATION	11
10.THE CHIP SIZE ON MODULE.....	12
10.1、 WTV040-44F2	12
10.2、 NAND-FLASH	13

1.FEATURES

- ◎ Re-recordable
- ◎ Voice can be record by Microphone/LINE IN or USB download.
- ◎ Customer change voices easily.
- ◎ With key mode and MCU serial mode
- ◎ MIC /LINE IN record sampling rate at 8KHZ, USB downloaded up to 24KHz.
- ◎ Equip with PC software , support WAV,MP3,ADPCM format, and support recorded voice upload.
- ◎ Low power consumption, suit for long time working .
- ◎ Record 256 groups of voice , duration up to 16 hours(depends on the NAND flash size)
- ◎ Operating voltage: 3.3V or 5V

+5V and +3.3V power input are optional .

2. BLOCK DIAGRAM

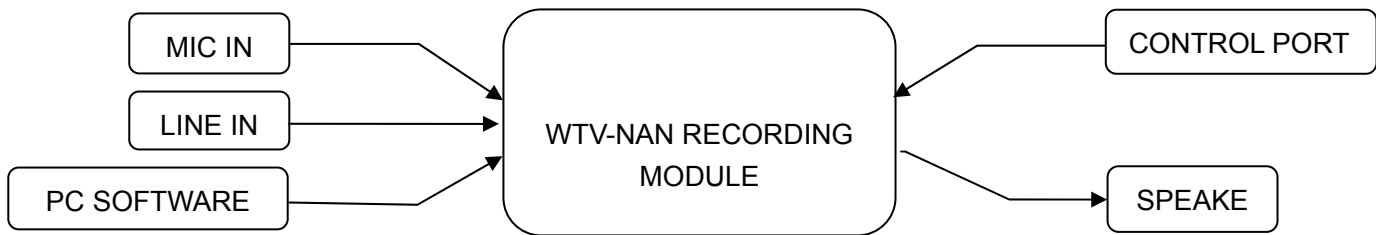

Description: Record voice to WTV-NAN module by MIC, LINE or PC software. Trigger module to play voice by control port. Support Samsung and Hynix 16MByte to 256MByte NAND-Flash .

3. WORDS AND EXPRESSIONS

◎MIC/LINE IN RECORD : Record voice by microphone or LINE IN.

◎PLAY RECORDED VOICE : Play the voice which recorded by microphone or LINE .

◎DOWNLOADED VOICE: Voice downloaded form PC by USB

4. APPLICATIONS

WTV-NAN is a multi-function module with record and playback function. Suit for long time high quality record applications. Such as fire protection record , meeting record, phone record, repeat machine, learning apparatus and so on.

Use in fire protection record, it can offer clues for analyzing the fire accident , fire alarm will be carry out when catch fire, and warning people.

5. PACKAGE AND PICTURE

1	+5V	UD-	28
2	DGND	UD+	27
3	P00	NC	26
4	P01	GND	25
5	P02	MIC+	24
6	P03	LINE-IN	23
7	RESET	NC	22
8	AUDIO-L	BUSY	21
9	SP-	+3.3V	20
10	NC	NC	19
11	SP+	P04	18
12	NC	NC	17
13	NC	P05	16
14	GND	P06	15

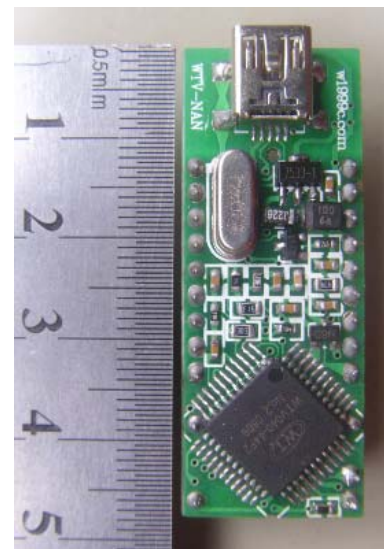

+5V and +3.3V power input are optional .

6.PINS DESCRIPTION

PIN	SYS.	DESCRIPTIONS	PIN	SYS.	DESCRIPTIONS
1	+5V	+5V Input	15	P06	SPI serial control ,DI
2	DGND	Digital GND	16	P05	SPI serial control , CLK
3	P00	MIC/LINE record	17	NC	NC
4	P01	Play voice downloaded by USB	18	P04	SPI serial control ,CS
5	P02	Play voice record by MIC/LINE	19	NC	NC
6	P03	Delete voice recorded by MIC/LINE	20	+3.3V	+3.3V Input
7	RESET	Reset	21	BUSY	SPI serial control, DO / play BUSY output
8	AUDIO-L	Positive Audio out to amplifier	22	NC	NC
9	SP-	To speaker negative	23	LINE-IN	Audio line in record
10	NC	NC	24	MIC+	Microphone positive
11	SP+	To speaker positive	25	GND	Analog GND
12	NC	NC	26	NC	NC
13	NC	NC	27	UD+	USB data pin
14	GND	Analog GND	28	UD-	USB data pin

7.CONTROL MODES

WTV—NAND recording module support KEY MODE and SPI SERIAL MODE.

Three seconds after electrify or reset , a “beep” sound and a USB indicator light glitter show module into working status. Downloaded voice can be deleted or changed only by pc software.(refer to “Usbrecorder” software use manual)

7.1 KEY MODE

In the KEY MODE, I/O functions

PIN	FUNCTIONS
P00 MIC/LINE IN record	ON/OFF control, First press to record group 1,second press to stop, third press to record next group.....
P01 Play MIC/LINE IN recorded voice	ON/OFF control, First press to play current group, second press to stop. Third press to play previous group.....
P02 Play downloaded voice	ON/OFF control, First press to play current group, second press to stop. Third press to play previous group.....
P03 Erase voice	Short press to erase current group of voice, press 3 seconds to erase all MIC/LINE IN recorded voice.

7.1.1.MIC / LINE IN RECORD DESCRIPTION

Negative edge trigger, first edge start to record, second edge to stop. Third edge to record next group. By parity of

+5V and +3.3V power input are optional .

reasoning.

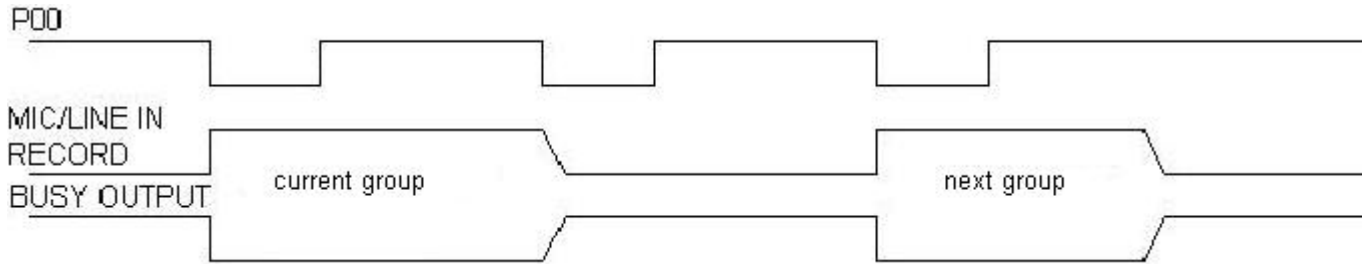

7.1.2.PLAY MIC/LINE IN RECORDED VOICE

Negative edge trigger, first edge start to play MIC/LINE IN recorded voice, second edge to stop it. Third edge to play previous group of voice. By parity of reasoning.

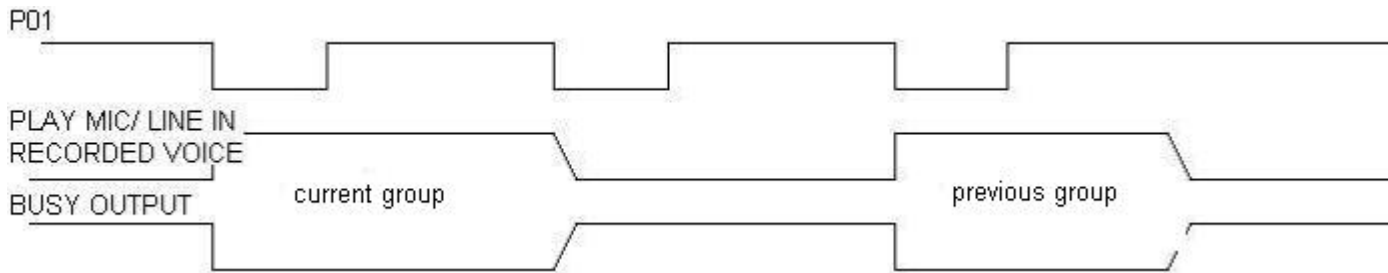

7.1.3. PLAY DOWNLOADED VOICE

Negative edge trigger, first edge start to play downloaded voice(download by software), second edge to stop it, third edge to play previous group. By parity of reasoning.

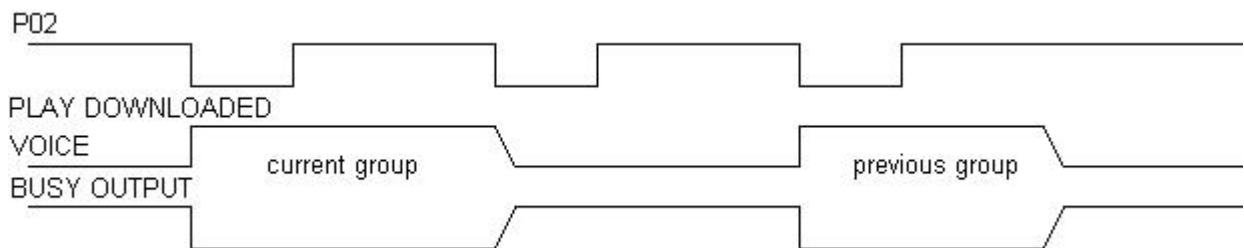

7.1.4.ERASE MIC/LINE IN RECORDED VOICE

Low level trigger, keep low level 1 second to delete current group of MIC/LINE IN recorded voice, Keep low level 3 seconds +5V and +3.3V power input are optional .

to delete all the MIC/LINE IN recorded voice(except first group recorded voice) . Downloaded voice can't be deleted by this way.

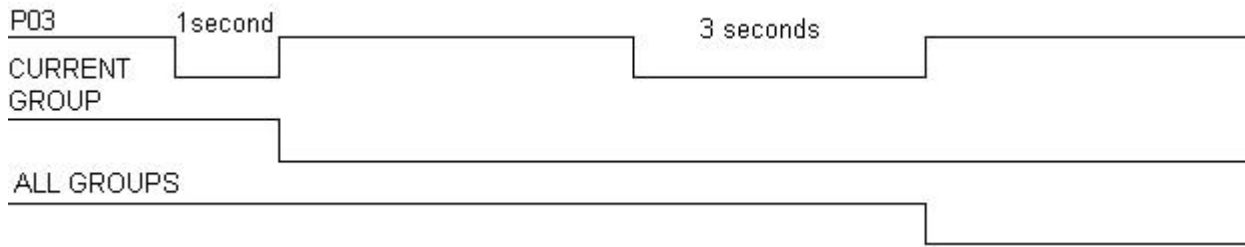

7.2.SPI SERIAL CONTROL

In this mode, I/O functions

PIN	FUNCTIONS
P00 MIC/LINE IN record	ON/OFF control, First press to record group 1,second press to stop, third press to record next group.....
P01 Play MIC/LINE IN recorded voice	ON/OFF control,First press to play current group, second press to stop. Third press to play previous group.....
P02 Play downloaded voice	ON/OFF control, First press to play current group, second press to stop. Third press to play previous group.....
P03 Erase voice	Short press to erase current group of voice, press 3 seconds to erase all MIC/LINE IN recorded voice.
P04	CS
P05	CLK
P06	DI
P07	DO/BUSY OUTPUT

7.2.1.CODE AND RELATIVE FUNCTIONS

CODE	FUNCTION	DESCRIPTIONS
FAH+00H	RECORD	Sequential record, duration is not limited within NAND-Flash size. BUSY pulled low . If the module is playing or recording, stop code must be sent before send this code.
FCH+XXH	PLAY (MIC/LINE IN recorded voice)	XXH represent group number, FCH+00H means play group 1 , BUSY pulled low at the beginning, pulled high at the end. If the module is playing or recording, stop code must be sent before send this code.
F7H+XXH	PLAY (downloaded voice)	XXH represent group number, F7H+00H means play downloaded voice 1, BUSY pulled low at the beginning, pulled high at the end. If the module is

+5V and +3.3V power input are optional .

		playing or recording, stop code must be sent before send this code.
FDH+XXH	ERASE (group)	XXH represent group number, FDH+01H means erase group 2, If the module is playing or recording, stop code must be sent before send this code. BUSY is low when erasing, BUSY is high when finish .
F5H+00H	ERASE (all groups)	Erase all MIC/LINE IN recorded voice, If the module is playing or recording, stop code must be sent before send this code.
F4H+00H	STOP	Stop playing or recording.
F8H+00H+16 BIT CLOCK	READ SPARE SPACE (F8H+00H+16 BIT CLOCK)	Read memory spare space

7.2.2.VOICE ADDRESSES

DATA (HEX)	FUNCTIONS
00H	Play group 0
01H	Play group 1
02H	Play group 2
.....
FDH	Play group 253
FEH	Play group 254
FFH	Play group 255

7.2.3. TIMING CHART FOR SENDING COMMAND

Pull low CS 2ms to wake up the module before sending command, then send out data at CLK rising edge. Send low first, control clock cycle within 200us~4ms. Structure is command+ data , send command before data, such as “FAH”, then “00H”. Pull low CS once only in this process. **BUSY and DO is the same port.** We suggest link reset(RST) to MCU'S I/O, MCU control reset , reset time :2ms. Module will work more stable.

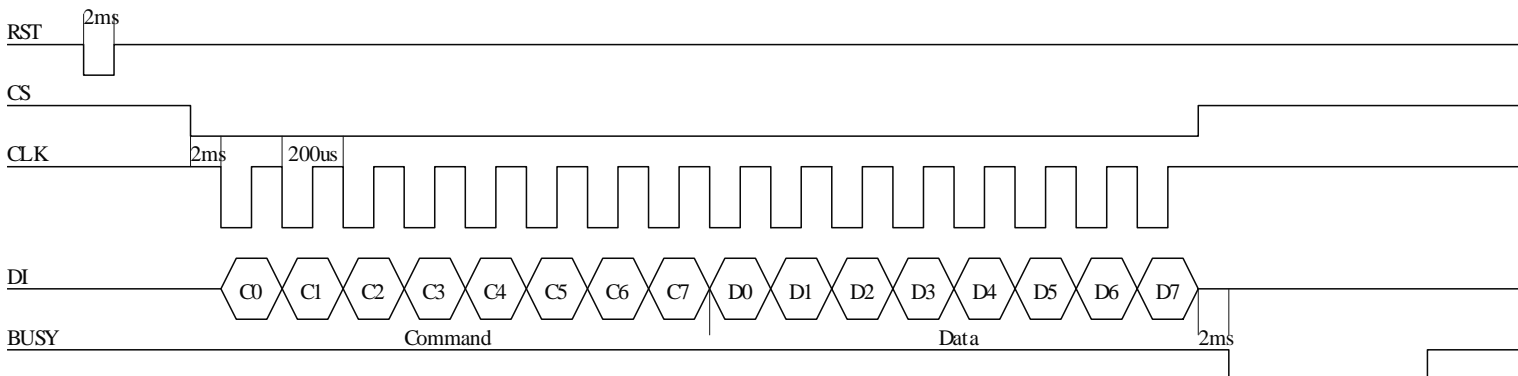

+5V and +3.3V power input are optional .

7.2.4. TIMING CHART FOR SENDING COMMAND TO READ THE SPARE SPACE

Pull low CS 2ms to wake up the module before sending command, then send out data at CLK rising edge. Send low first, control clock cycle within 200us~4ms. Structure is command+ data+16bit CLOCK , send command(F8H) before data(00H) then send 16 bit clock . wait for 1 second, MCU receive DO data, after finish , pull high CS. BUSY and DO is the same port. When DO reading return code ,C 7 still high level as "1" , we have to shield it as "0" for reading correct memory spare space.

The minimum unit is 16kbyte for 16M to 64M NAND-Flash, The minimum unit is 128kbyte for 128M to 256M NAND-Flash. Take 32M for example, reading the hex value is "0X82CD" , shield the highest bit, and the hex virtual value is "0X82CD" , and multiply 16KByte , the spare space is 11.2MByte.

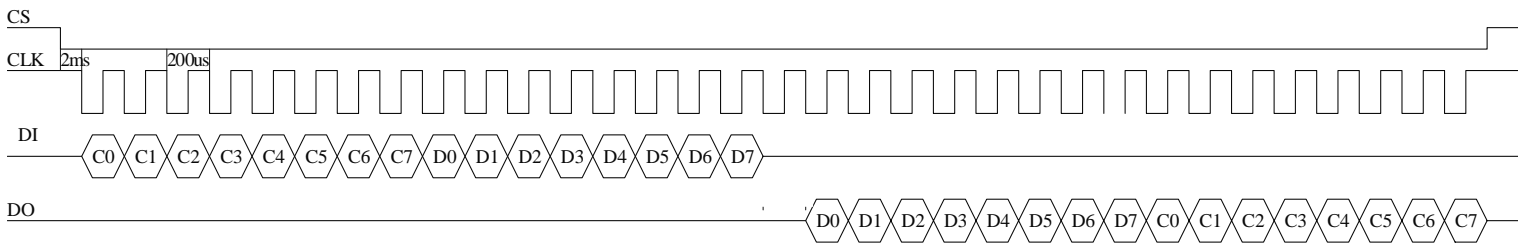

8. APPLICATION CIRCUIT

8.1. WTV-NAND MODULE INNER CIRCUIT

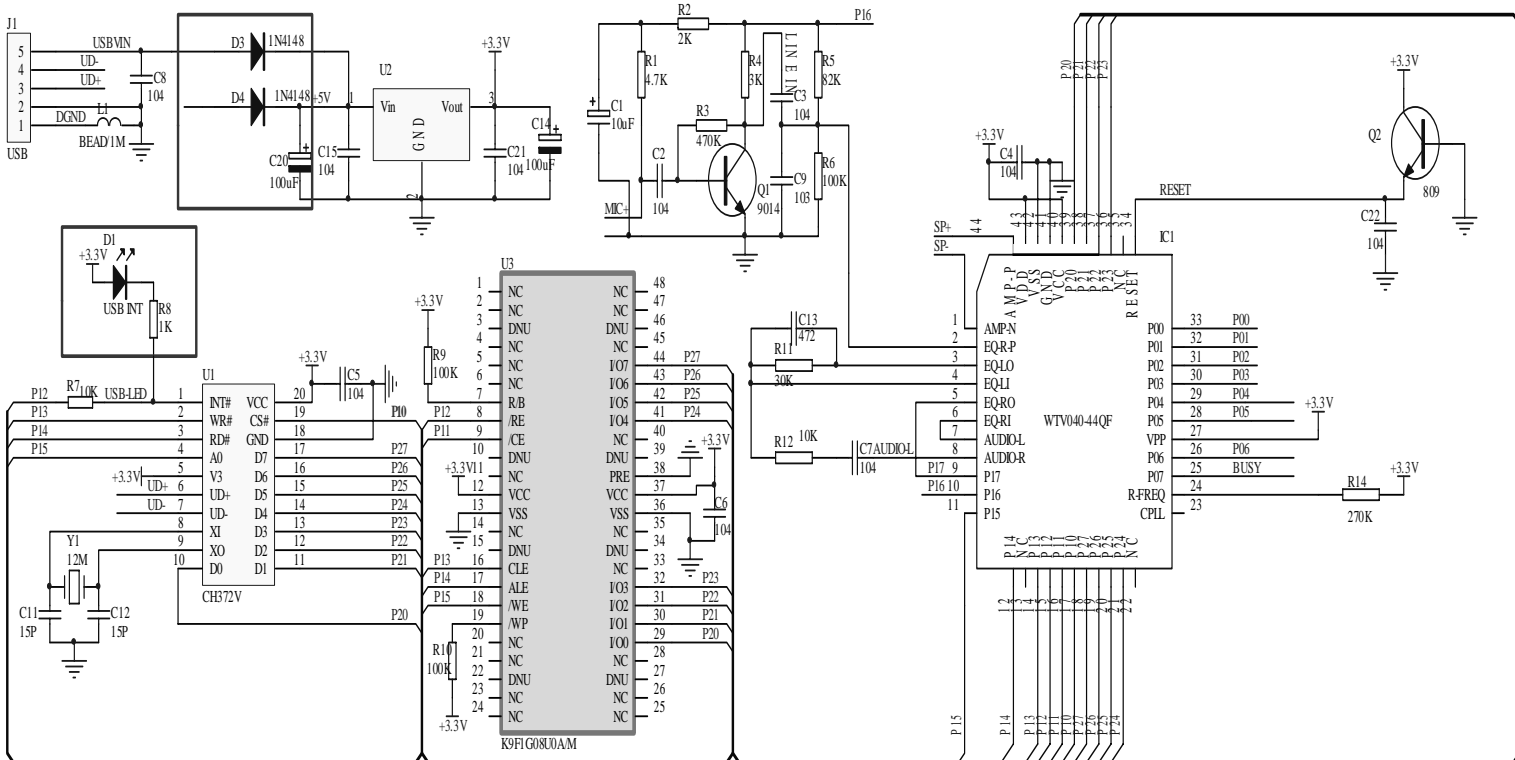

+5V and +3.3V power input are optional .

8.2.KEY MODE (PWM OUTPUT)

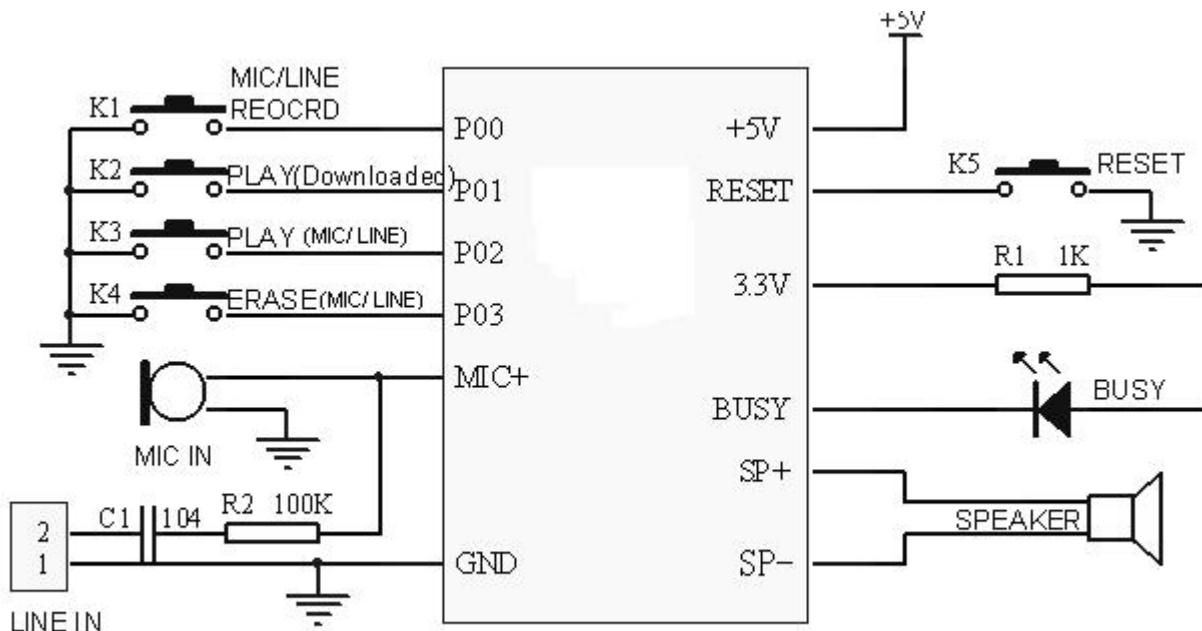

WTV-NAND RECORDING MODULE

Circuit description: In Key mode , P00 ,P01 ,P02 ,p03, corresponding key K1, K2, K3, K4 default as MIC/LINE IN record , PLAY (downloaded voice) , PLAY (MIC/LINE IN recorded voice) , ERASE (MIC/LINE IN recorded voice) individually . BUSY output also for playing busy , low level at play or record status. Microphone connect to “MIC+”, LINE IN connect to “MIC+” after go through C1 and R2 . Reset connect to K5 , negative edge trigger and low level (50ms) can trigger to reset .

PWM output can direct drive 0.5W/8Ω speaker .

8.3.KEY MODE (DAC OUTPUT)

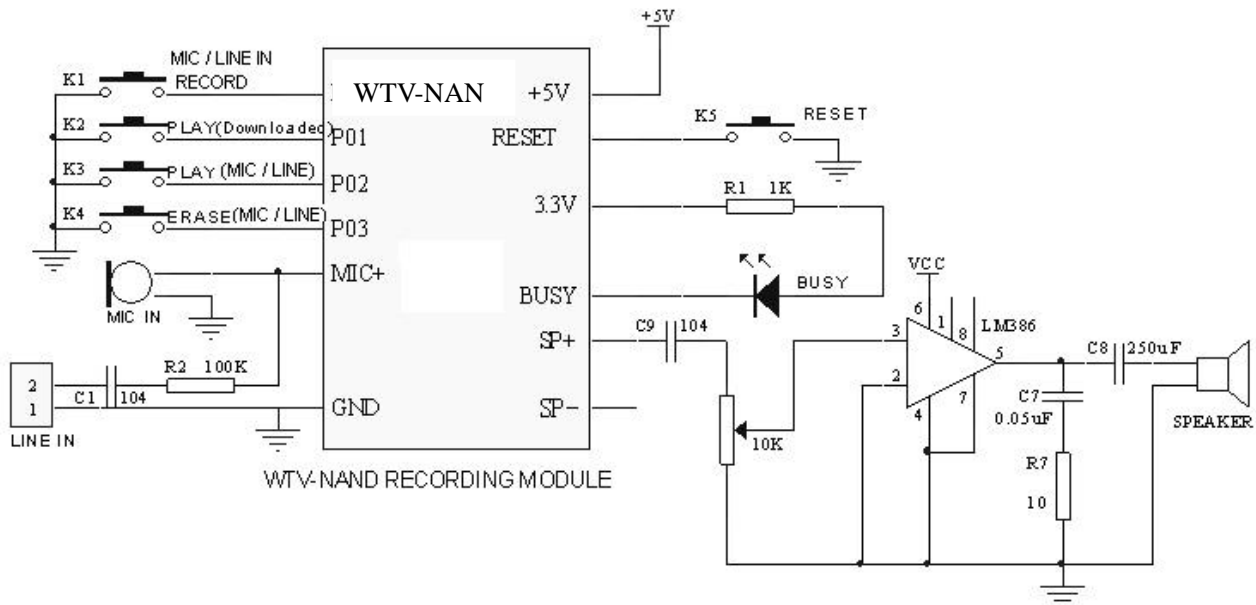

Circuit description : Key mode , P00 ,P01 ,P02 ,p03, corresponding key K1, K2, K3, K4 default as MIC/LINE IN record , PLAY (downloaded voice) , PLAY (MIC/LINE IN recorded voice) , ERASE (MIC/LINE IN recorded voice) individually . BUSY output also for playing busy , low level at play or record status. Microphone connect to “MIC+”, LINE IN connect to “MIC+” after go through C1 and R2 . Reset connect to K5 , negative edge trigger and low level (50ms) can trigger to reset .

DAC output , “SP +” connect to amplifier audio in positive , audio in negative connect to module GND , “SP –” NC .

8.4.SPI SERIAL CONTROL MODE (PWM OUTPUT)

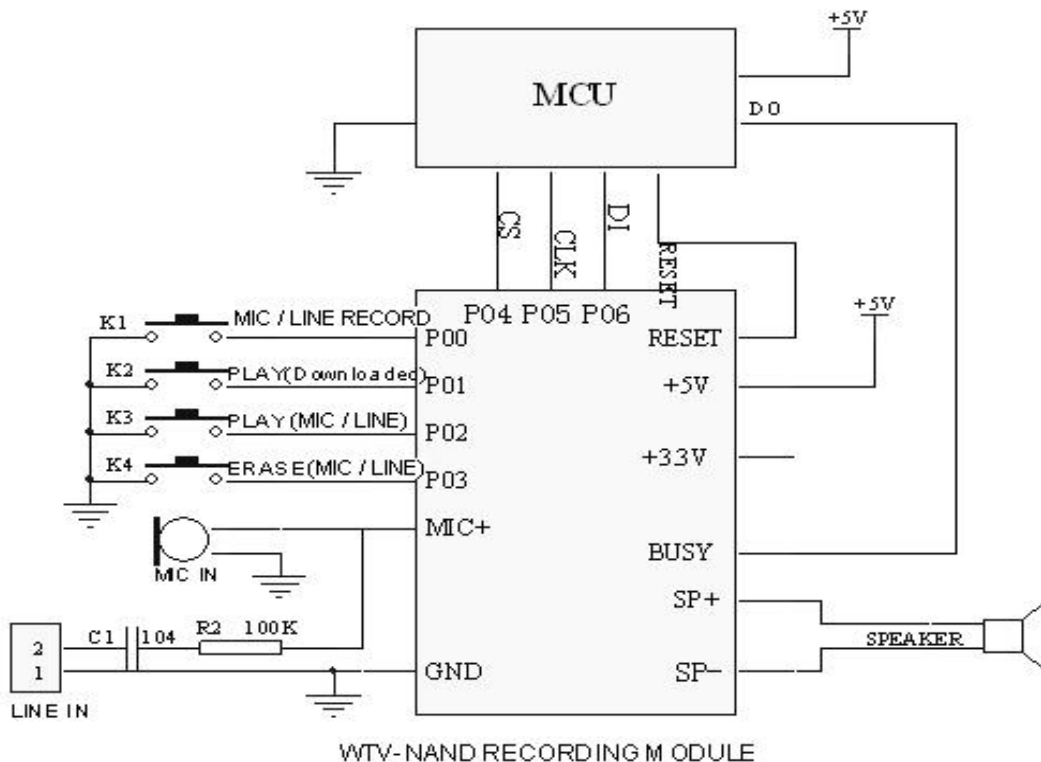

Circuit description : In the serial control mode , P00 ,P01 ,P02 ,p03, corresponding key K1, K2, K3, K4 default as MIC/LINE IN record , PLAY (downloaded voice) , PLAY (MIC/LINE IN recorded voice) , ERASE (MIC/LINE IN recorded voice) individually . MCU control module to work(such as play , record, reset) by CS ,CLK ,DI ,DO (busy port) connect reset to MCU, module reset controlled by MCU . Microphone connect to “MIC+”, LINE IN connect to “MIC+” after go through C1 and R2 . Reset connect to K5 , negative edge trigger and low level (50ms) can trigger to reset . PWM output, direct drives 0.5W/8Ω speaker.

8.5.SPI SERIAL CONTROL MODE (DAC OUTPUT)

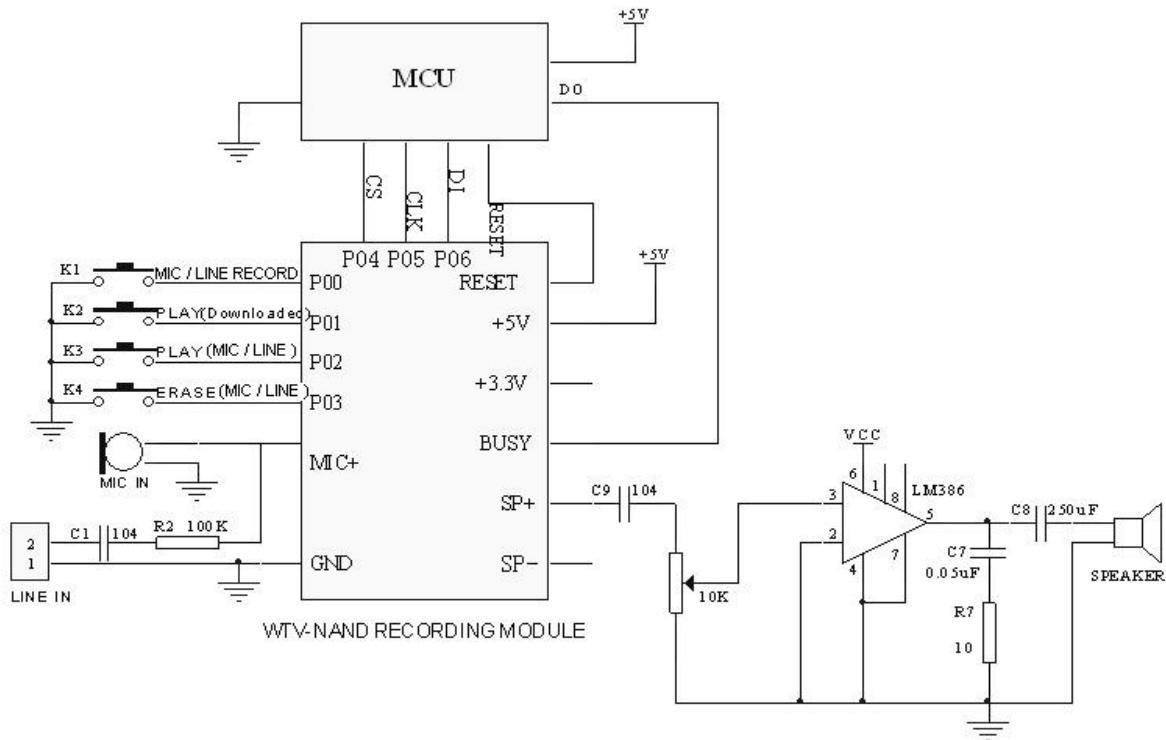

Circuit description : In the serial control mode , P00 ,P01 ,P02, p03, corresponding key K1, K2, K3, K4 default as MIC/LINE IN record , PLAY (downloaded voice) , PLAY (MIC/LINE IN recorded voice) , ERASE (MIC/LINE IN recorded voice) individually . MCU control module to work(such as play , record, reset) by CS ,CLK ,DI ,DO (busy port) connect reset to MCU, module reset controlled by MCU . Microphone connect to “MIC+”, LINE IN connect to “MIC+” after go through C1 and R2 . Reset connect to K5 , negative edge trigger and low level (50ms) can trigger to reset . PWM output, direct drives 0.5W/8Ω speaker.

DAC output , “SP +” connect to amplifier audio in positive , audio in negative connect to module GND , “SP –“ NC .

9.SUPPLY INFORMATION

MODEL	PACKAGE	MEMORY SIZE	DURATION	PICTURES
WTV-NAND	DIP28	16MB	1 hour (at 8KHz)	
WTV-NAND	DIP28	32MB	2 hours (at 8KHz)	
WTV-NAND	DIP28	64MB	4 hours (at 8KHz)	
WTV-NAND	DIP28	128MB	8 hours (at 8KHz)	
WTV-NAND	DIP28	256MB	16 hours (at 8KHz)	

+5V and +3.3V power input are optional .

10. THE CHIP SIZE ON MODULE

10.1. WTV040-44F2

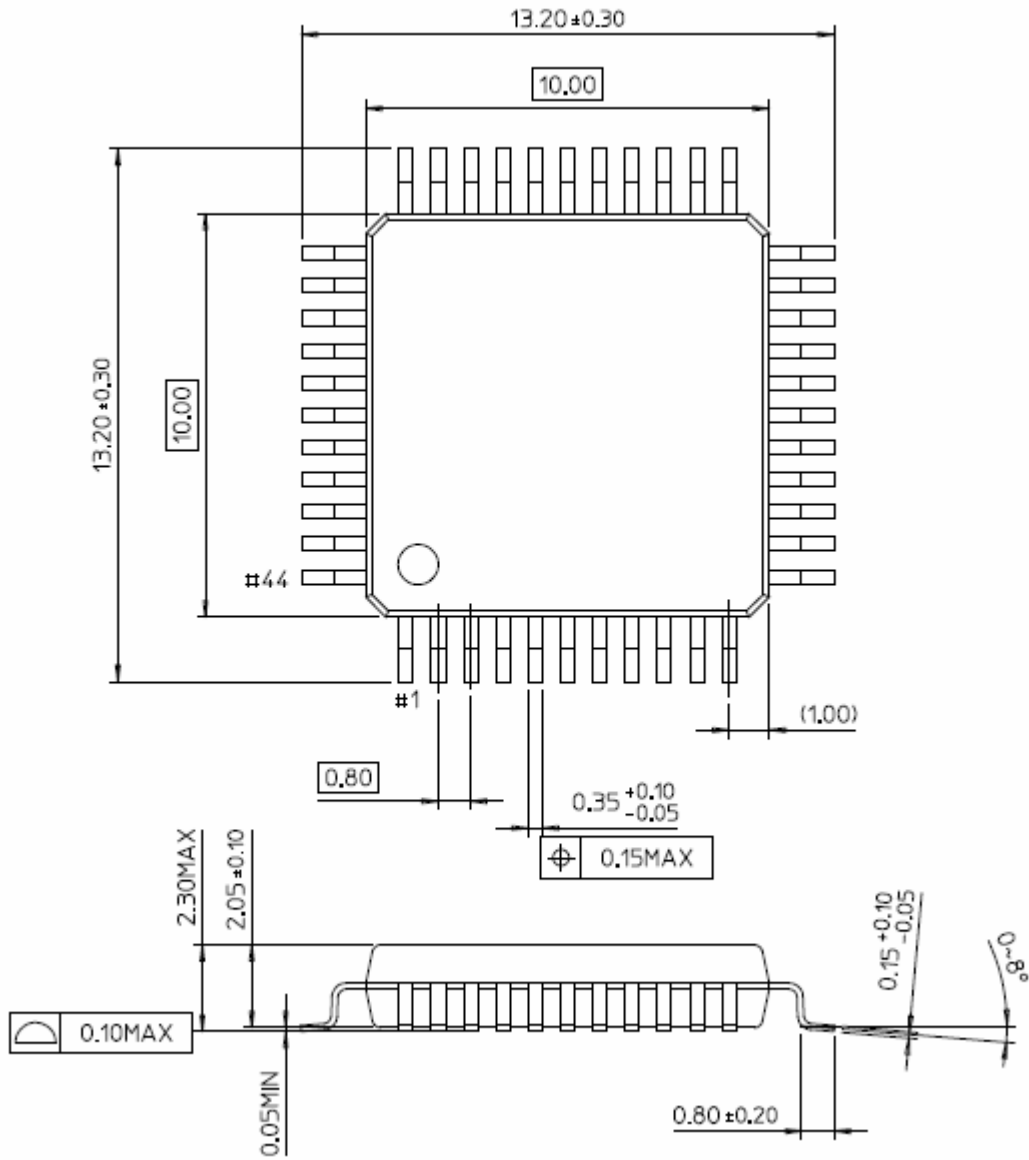

+5V and +3.3V power input are optional .

10.2、NAND-FLASH

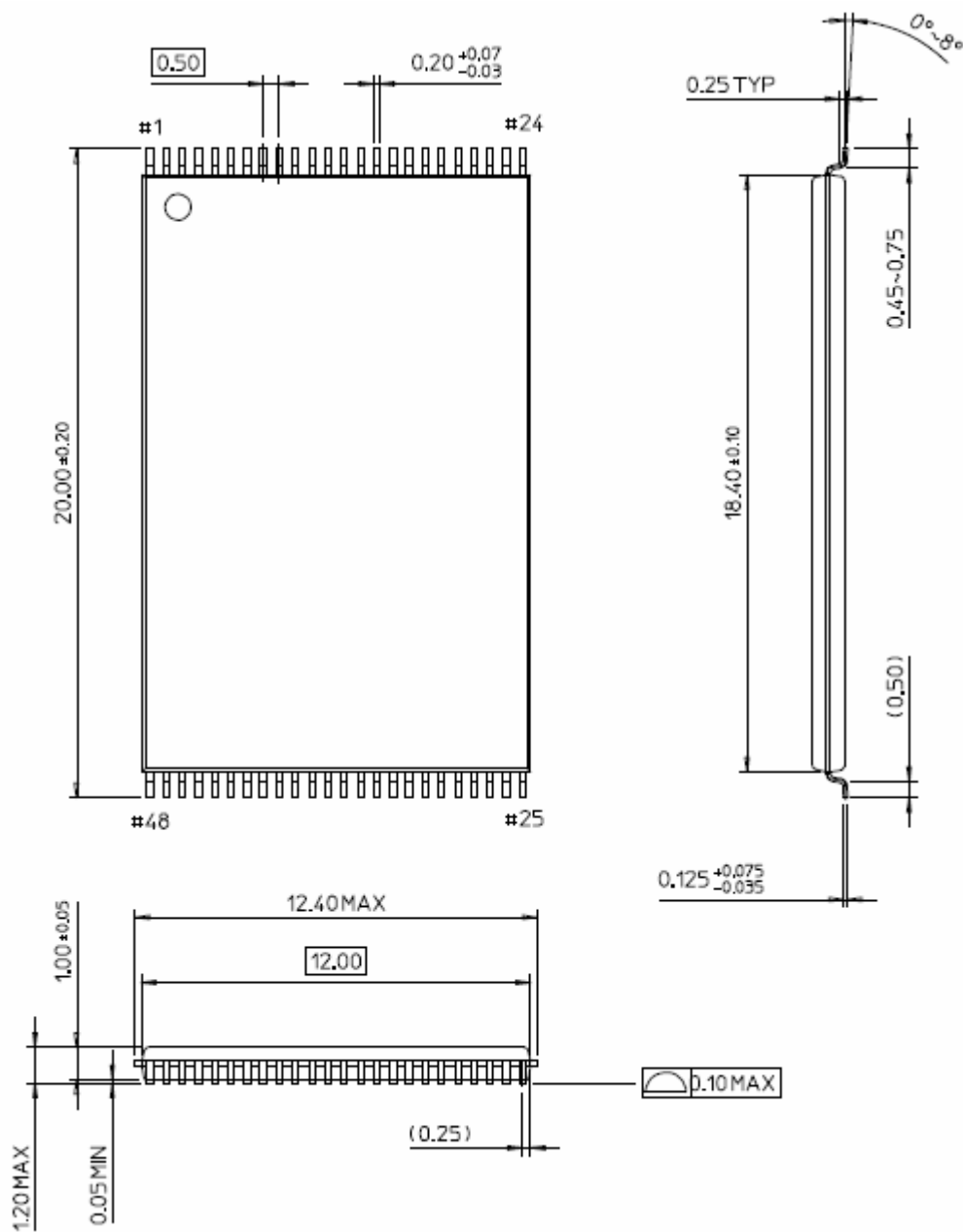

11. VERSIONS

VERSION	DATE	DESCRIPTION
V1.2	2008-11-4	ORIGINAL

+5V and +3.3V power input are optional .